

LOW MAINTENANCE

IDEAL COMFORT

CHILLED BEAMS

EFFICIENT AIR DIFFUSION
SALES BROCHURE



CHILLED BEAMS

SUPERIOR INDOOR AIR QUALITY WITH MINIMAL ENERGY CONSUMPTION

With the majority of the population spending 90% or more of their day indoors, indoor air quality is more important than ever before. Indoor air quality is dependent upon comfortable room temperatures, humidity control and the elimination of any pollutants within the building. Excellent indoor air quality is not only important for the comfort of building occupants, but it also affects their overall health. It has been proven that indoor air quality also plays a vital role in a person's productivity. Recent studies have shown that when a building has optimized air quality, occupants are 5-10% more productive, resulting in smarter students and better employees.

FläktGroup SEMCO's chilled beam line was engineered to provide optimal comfort and indoor air quality to building occupants. In addition to improving comfort levels, chilled beams can also help minimize energy costs and reduce the architectural impact of ductwork and other mechanical systems. Chilled beams are best suited for applications where there is a high sensible cooling load and/or areas that require individual comfort control such as offices, schools, universities, medical buildings, hospitals, hotels and restaurants.

FläktGroup SEMCO's chilled beam line is able to manage high cooling capacity by using the building's primary air supply, generally outdoor air, to induce airflow over the chilled beam's coil element. Once the air passes over the coil, it is supplied to the area through the diffusers built into the beam. Many of FläktGroup SEMCO's beams have a patented airflow system, allowing airflow patterns to easily be adjusted to meet the changing conditions of any given space.

Integrating FläktGroup SEMCO chilled beams into to an existing HVAC system or adding them to a new FläktGroup SEMCO energy recovery system will reduce a building's energy consumption, help it comply with ASHRAE standards and lower its operational costs. With chilled beams, most of the sensible heating and cooling capacity is provided by water coils instead of ventilation air, reducing the amount of energy used by fans and other equipment. In addition to lowering energy and operational costs, chilled beams have a low life cycle cost and are very easily cleaned and maintained.



INDOOR AIR QUALITY

- AIR TEMPERATURE +
- HUMIDITY +
- AIR QUALITY +
- AIR VELOCITY +
- SOUND LEVEL +
- LIGHTING LEVEL +
- CLOTHING & ACTIVITY

COMFORT

90% of modern living is spent **indoors.**

HOW CHILLED BEAMS OPTIMIZE COMFORT

FULLY MIXED AIR — low temperature gradients

LOW NOISE — no fan

FRESH AIR — right humidity and temperature

EVEN AIR DISSEMINATION — no pockets of concentrated air



CHILLED BEAM TERMINOLOGY

COMFORT CONTROL FUNCTION

The chilled beam comfort control function, uses the beam's adjustable induction system to regulate the needs of a space by diffusing air in up to four directions. The air may be diffused in either a symmetric or dissymmetric flow, which can be redirected at any time.

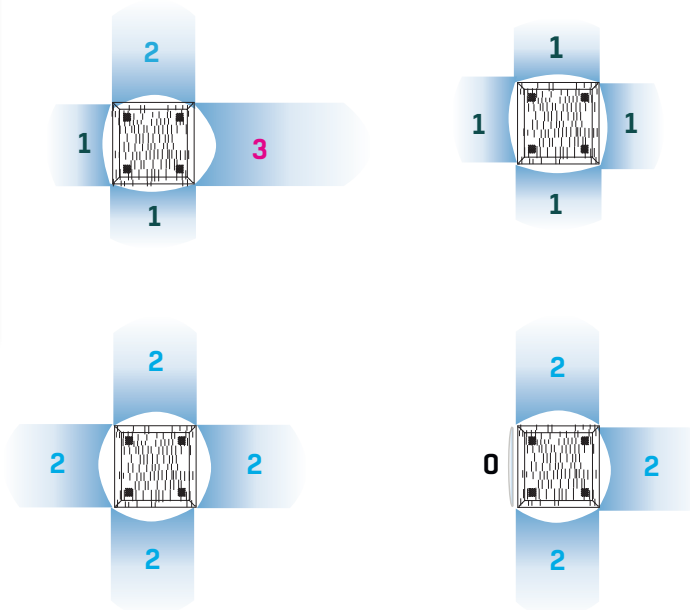

Air flow patterns in the above example are only available on the LYRA II

COANDA EFFECT

The Coanda effect is achieved by directing airflow tight to the ceiling, allowing greater throw distance and less noticeable drafts than diffusers aimed down into the occupied zone.

COANDA SAFETY CONTROL

The Coanda safety control maintains the Coanda effect while simultaneously ensuring the highest possible cooling power by maneuvering the front panel up and down. At low flows and pressures the front panel should be moved up to its highest position and during high flows and pressures the front panel should be reconfigured to its lowest position. By adjusting the front panel heating and cooling power can be increased by approximately 5-10%.

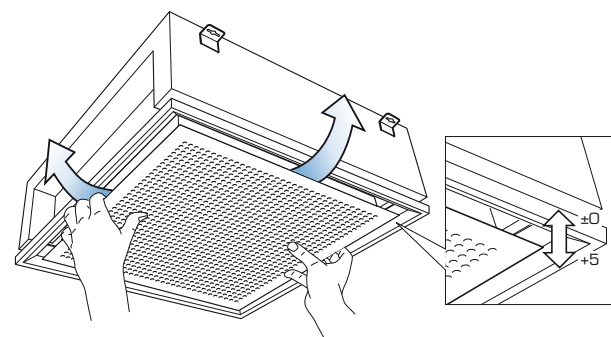

PRESSURE INDEPENDENT ACTUATOR (Pi)

The Pi actuator is an optional flow control device, that can be mounted directly to the LYRA II, NOVA II and ORION II, allowing ventilation flow to adjust in response to changes in demand or upstream pressure. Attaching a Pi actuator to a chilled beam, allows the chilled beam to be even more flexible in terms of its ability to quickly adapt to constantly changing space conditions. The Pi actuator adjusts the nozzles to allow only the amount of ventilation flow needed for current occupancy levels, regardless of the pressure changes occurring in the ductwork system. Air quality can also be monitored, because there is a CO₂ sensor connected to the controller.

Unlike competitor's pressure independent controls, which can only be used with larger static pressure regain duct systems, the Pi actuator can be used with any duct system. Since it can be used in combination with any duct system, it is easy for engineers to incorporate the NOVA II, LYRA II and ORION II into their designs and can be easily and quickly removed and installed on another beam. In cases of redesigns or remodels, the Pi actuator may be retrofitted to meet updated needs.

The demand control ventilation feature of the Pi actuator, allows chilled beams to be even more energy efficient, due to its three modes; unoccupied, standard occupancy and high occupancy, which determine exactly how much air is needed in a given zone and only turn the air nozzles on if the zone's occupancy demands it. Unoccupied mode, provides a minimum primary air flow for the induction required to allow the beam's coil to satisfy the zone's sensible demand. While occupied mode provides the required primary air flow for the zone.

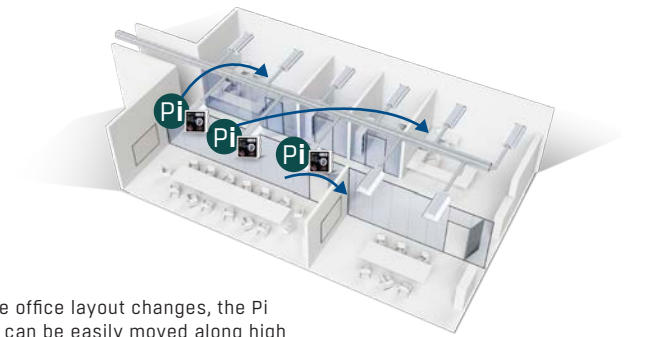

When the office layout changes, the Pi actuator can be easily moved along high occupancy rooms – simply disconnect, re-connect and re-set the values.

FLOW PATTERN CONTROL

Flow pattern control is the configuration of plastic blades located inside the diffusion system. The configuration of blades determines how far and in what direction the air throw will go. The configurations can be set without tools and should be set to optimize air diffusion.

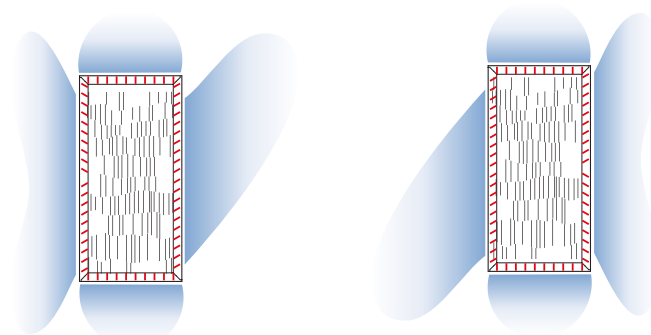
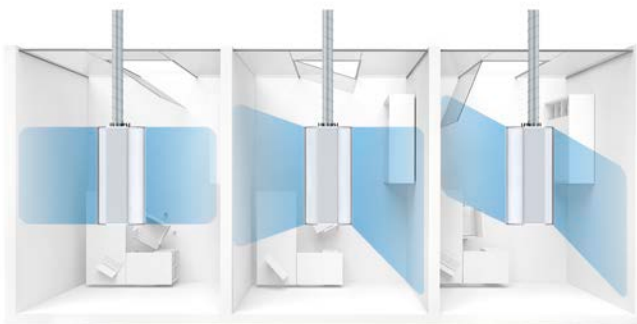

An example of the LYRA II in a high airflow application at a symmetrical setting, where flow pattern control blades are set a 30° angle to avoid the colliding air streams from opposing chilled beam units. This throw pattern is unique to the LYRA II.

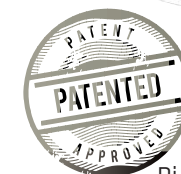

Pi Actuator



JUNO IQHC

ACTIVE CHILLED BEAM

FEATURES

- Length 2'-10' (available 1' increments)
- Adjustable primary flow (energy control)
- Adjustable air diffusion (flow pattern control)
- Easy installation (fastening brackets – cable or all-thread suspension)
- Cooling and/or heating (2 or 4 pipe coil) or dual (2 pipe) circuit coil
- Flexible, universal air and water connection
- Flush mounting in lay-in or gypsum board ceiling or exposed
- Easy to clean and maintain
- Coanda wing and security style options available

The Juno IQHC active chilled beam is one of the most versatile beams on the market. Unlike competitor's chilled beams, which rely upon fixed air nozzles, the Juno IQHC has multiple knockout locations for air inlet and field adjustable slot configurations for primary air. The lack of fixed air nozzles allows engineers to base their designs around a single termination pressure, making it significantly easier to design around, install and balance.

Generally, chilled beams are designed to regulate air temperature by flowing primary air in through nozzles

and inducing air from a space up through cooling coils. The Juno IQHC, on the other hand, utilizes a knockout to bring in air and then routes it over the low pressure coils, where it is cooled to the desired room temperature. By forcing the low pressure coil to do the bulk of the cooling, fan horsepower usage is reduced, as well as, overall energy expenditure.

The Juno IQHC is aesthetically pleasing, with an attractive perforated swing down that optimizes room air induction and maximizes efficiencies. Individual room comfort can be easily maintained with adjustable air-flow patterns.

COIL COOLING POWER: 8' BEAM

(.5" Beam Pressure, 58°F Water and 76°F Room Temperature, GPM)

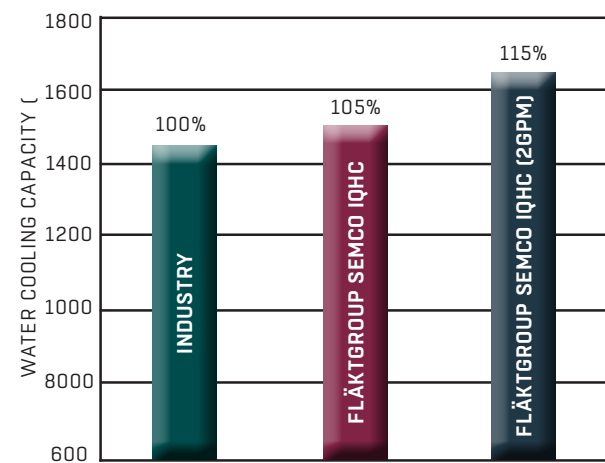

Comparison of coil cooling power provided by the previous top performing chilled beam (benchmark) against the new IQHC beam shown at the same water flow (yellow) as an industry standard, and at the same water-side pressure loss/pump energy used (green).

SLOT ADJUSTMENT 1

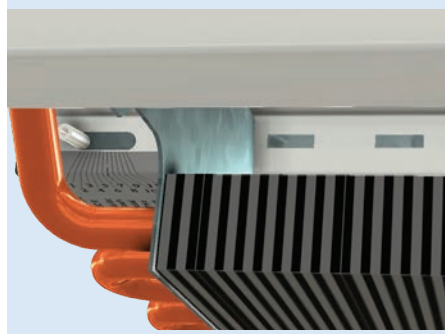

SLOT ADJUSTMENT 2

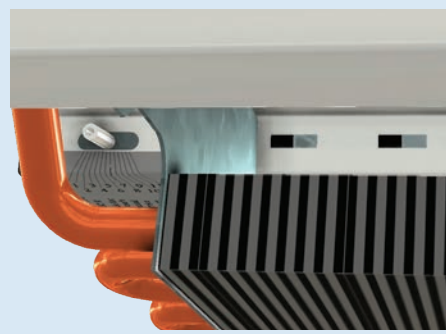

SLOT ADJUSTMENT 3



Highest industry cooling capacity



Lowest pressure air and water high capacity beam



Reliable operation and long life expectancy

LYRA II IQCC

CASSETTE CHILLED BEAM

The FläktGroup SEMCO Lyra II IQCC compact cassette chilled beam combines high cooling capacity with a high level of comfort. Lyra II IQCC is capable of diffusing air in up to four directions. By mixing ventilation air with ambient air, the Lyra II IQCC can efficiently cool or heat a zone, based on the current conditions. The Lyra II IQCC can quickly adapt to frequently changing conditions, with easily adjustable nozzles and diffusers with flow pattern control.

If the Coanda Effect is a concern, an optional Coanda safety control function is available. The Coanda safety control keeps the air trapped by the Coanda Effect, stationary, while also delivering the highest possible cooling to a space. The perforated panel on the Lyra II can easily be manoeuvred up and down to balance the airflow and pressure needed to maintain the Coanda Effect.

Virtually undetectable, the Lyra II IQCC is one of the quietest chilled beams on the market. It operates at less than 20 dB for a single cassette installation and less than 25 dB for a three cassette installation.

LYRA II IQCC INSTALLATION TYPES

- Gypsum board installation available in 60 cm x 60 cm and 60 cm x 120 cm
- Exposed installation with optional enclosure available in 60 cm x 60 cm and 60 cm x 120 cm
- High flow version available in 60 cm x 60 cm and 60 cm x 120 cm

QUICK SELECTION

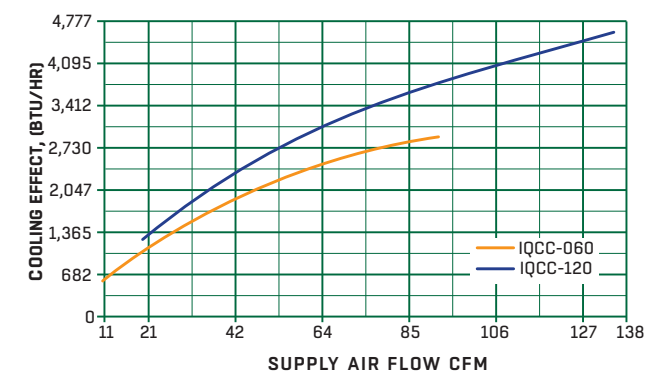

The diagram shows the approximate cooling power P_{cool} in BTU/Hr with water flow $Q_w = 0.05$ CFM, temperature difference between room air and supply air $\Delta t = 46^\circ$ F. Temperature difference between mean water temperature and room temperature, $\Delta = 46^\circ$ F. Temperature difference between mean water temperature and room temperature, $\Delta t = 46^\circ$ F. Total air pressure drop 70Pa.

FEATURES

- Length 60 cm x 60 cm and 60 cm x 120 cm
- Ventilation
- Compact chilled beam
- Adjustable injunction (energy control)
- Adjustable air diffusion (flow pattern control)
- Easy installation (fastening brackets)
- Can be recessed or exposed
- Heating and cooling
- Easy to clean and maintain
- Coanda safety control
- Energy efficient, saving money on operating and life-cycle costs.
- Flexible diffusion lay out
- Integrated control for plug and play installation

OPTIONS

- Pressure independent (Pi) actuator
- Demand controlled ventilation with Pi actuator
- Retrofit options are available with the Pi actuator
- Custom paint colors



High cooling capacity



Very low noise levels



Reliable operation and long life expectancy



NOVA II IQFI

EXPOSED ACTIVE CHILLED BEAM

FEATURES

- Length 120 cm - 300 cm (every 30 cm)
- Ventilation, heating and cooling
- Adjustable induction (energy control)
- Adjustable air diffusion (flow pattern control)
- Easy installation (fastening brackets)
- Exposed; free-hanging, ceiling mount
- Water coil heating and/or cooling (2 or 4 pipe coil)
- Easy to clean and maintain
- Energy efficient, saving money on operating and life-cycle costs.
- Nozzles: 0-36 mm
- Factory mounted controls
- Perforated swing down front panel for easy access

OPTIONS

- Round or square shape beam
- Pressure independent (Pi) actuator
- Custom paint option
- Controls

The NOVA II IQFI is an exposed, active chilled beam, that can be used to heat, cool and ventilate a zone. Like the LYRA IQCC and the Juno IQHC, the NOVA II IQFI comes equipped with adjustable blades, for flow pattern control and adjustable induction to achieve optimal comfort and flexibility.

With the addition of the, optional, Pi actuator, the NOVA II IQFI becomes pressure independent, making it suitable to be used with any ductwork system and for retrofitting. Installing the Pi actuator also allows the NOVA II IQFI to employ a demand controlled ventilation function, which will determine airflow levels based the occupancy of a space, further increasing the NOVA II IQFI's efficiency, flexibility and comfort. Without the Pi actuator, the airflow nozzles would have to manually adjusted with a screwdriver.

The NOVA II IQFI is an aesthetically pleasing, ceiling-mounted, exposed, active chilled beam. It is available in a round or square shape.



QUICK SELECTION

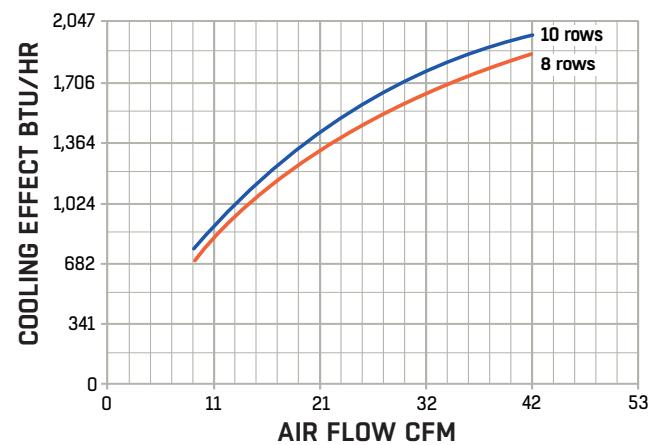

The diagram shows that the total cooling effect per btu/hr at a total pressure of 70 Pa, water flow $q_w = 0.11$ CFM, temperature difference between room air supply and supply air $\Delta t = 46^\circ\text{F}$ and supply air $\Delta t = 46^\circ\text{F}$ and temperature difference between mean water temperature and room temperature $\Delta t = 46^\circ\text{F}$.



AURORA IQSA

CHILLED BEAM

The Aurora IQSA, is an active chilled beam suited for heating, cooling and ventilation. Engineered to mix ambient and supply air, to provide high cooling capacities in combination with comfort and low air velocities.

Zone temperatures and airflow patterns can easily be maintained or adapted to meet changing zone conditions with the adjustment of the diffuser blades.

The Aurora IQSA is a ceiling mounted chilled beam, which was dimensionally designed to perfectly fit into 12" ceiling grids. Due to its covered top-side, straight or slanting duct and water connections may be used, making the Aurora IQSA extremely flexible.

FEATURES

- 1' wide, 4'-10' long in 2' steps
- Ventilation, heating and cooling
- Adjustable induction (energy control)
- Easy installation – cable hanging or fastening brackets
- Ceiling mount – suited for a standard narrow 1' x 2' ceiling space
- Easy to clean and maintain
- Energy efficient, saving money on operating and life-cycle costs
- Factory mounted controls
- Perforated bottom panel is segmented for easy access

OPTIONS

- Custom paint option
- Controls

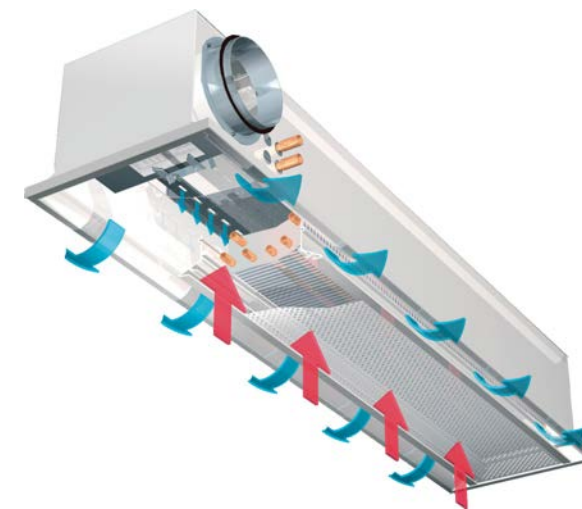

QUICK SELECTION

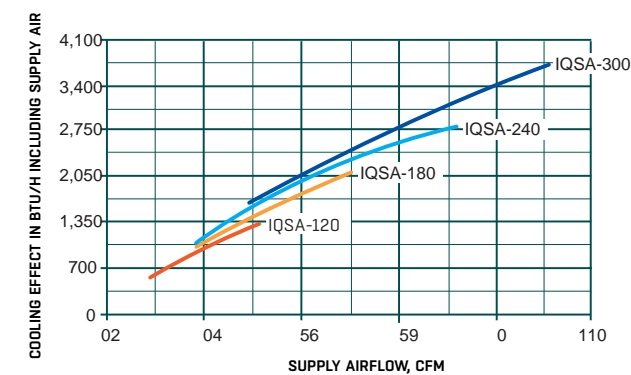

The diagram shows the approximate cooling effect P_{cool} in btu/h with water flow $q_w = 0.8$ GPM, temperature difference between room air and supply air $\Delta t = 46.4^\circ\text{F}$, difference between room and average water temperature = 46.4°F , pressure drop 0.25 inwg on the air side and maximum sound pressure $L_{A10} = 34$ dB(A).



Reliable operation and long life expectancy



Flexible Installation



Heating and cooling

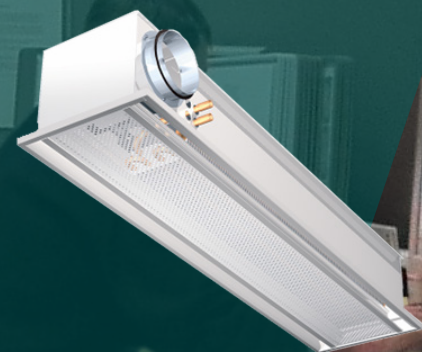

ORION II IQHA

BULKHEAD MOUNTED BEAM

FEATURES

- 60 cm wide, lengths 100 cm - 160 cm increments
- Available in four sizes
- Ventilation, heating and cooling
- Adjustable primary airflow with 36 nozzle settings
- Easy installation (fastening brackets, with all controls fitting in the chilled beam tray and adjustable installation height)
- Bulkhead mount
- Energy efficient, saving money on operating and life-cycle costs.
- Perforated swing down front panel for easy access
- Beam ships without a discharge grille for applications with grilles by others. Optional grilles with spring clamp installation with fixed blades, horizontally adjustable blades, or horizontally and vertically adjustable blades are available.
- Easy to clean and maintain

OPTIONS

- Pressure independent (Pi) actuator
- Demand control ventilation with Pi actuator
- Custom paint option
- Controls

APPLICATIONS

- Hotels
- Hospitals
- Offices

The Orion II IQHA is an active, bulkhead mounted chilled beam used for ventilation, heating and cooling. Inconspicuous with sound pressure less than 20dB, the Orion II IQHA, is perfect for hotel rooms, hospital rooms and offices.

Inherently flexible, the Orion II IQHA can easily be adapted to meet changing temperature needs with three diffusion grilles and adjustable blades. Adding a Pi actuator to the Orion II IQHA increases its flexibility and makes it more efficient, because it adds demand-controlled ventilation — a control which allows a chilled beam to function in an occupancy dependent way. The Pi actuator also permits the Orion II IQHA to be pressure independent, allowing the Orion II IQHA to work with any duct system or to be retrofitted. .



QUICK SELECTION

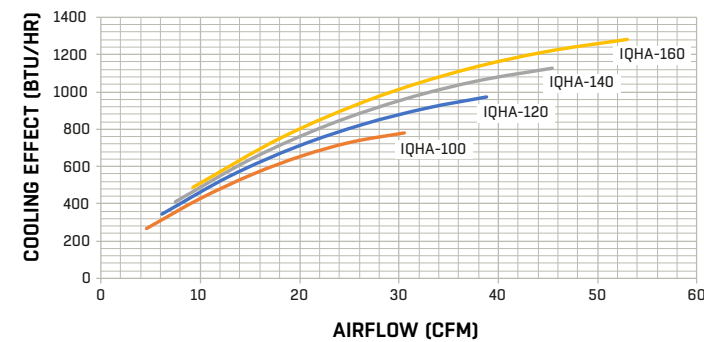

Total cooling effect with grille (adjustable horizontal blades) at a total pressure of 70 Pa, water flow $q_w = 0.79$ GPM, temperature difference between room air and supply air $\Delta t = 46.4^\circ\text{F}$ and temperature difference between mean water temperature, and room temperature $\Delta t = 46.4^\circ\text{F}$



Very low noise levels



Pi actuator option



Flexible Installation

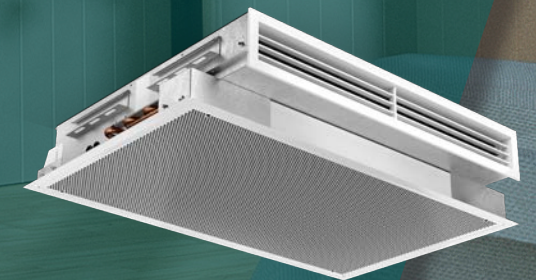

NEUTON™

PUMP MODULE

FEATURES

- Active condensation control system
- Reduces the cost of chilled beam installation by 30% or more for smaller pipe diameter fittings and feet of pipe.
- Cuts the amount of zone pipings and fittings in half by removing the need for building-level secondary loops for the chilled beams.
- Simplifies installation, controls and beam system commissioning.
- Increases beam cooling and heating output, allowing all coil passes to be used for cooling and heating.
- Eliminates the confusion and cost of customized zone control development and installation.
- Improved response to occupied/unoccupied and low load conditions – novel control sequences vary water flow and/or temperature, as needed, to accommodate changes in load conditions.

OPTIONS

- Single zone (controls up to 10 chilled beams) or Multi-zone (controls up to 15 chilled beams)
- Three different pump configurations: Neuton™ Chilled beam pump module (CCPM)-11, Neuton™ CCPM-20 and Neuton™ CCPM-30
- The Neuton²™ – single actuator for summer/winter switchover or Neuton⁴™ – dual actuator for simultaneous heating and cooling.

APPLICATIONS

- Schools, offices, hospital rooms, hotels, nursing homes

One of the biggest concerns, when deciding to incorporate chilled beams into an HVAC system, is the cost of additional primary and secondary piping, required for the installation. This issue can easily be resolved by linking a Neuton™ pump module to the chilled beam system. The Neuton™ easily connects to the primary and zone piping loops with smaller piping and fittings, while eliminating the need for a secondary chilled and heated water loop. With the reduction in the size of fittings and piping, chilled beam installation costs are cut at least 30%, making them competitive with traditional systems.

Without a secondary heating or cooling loop, the Neuton™ can use entering water at 42°F (for cooling) and 120°F (for heating) to dedicated outdoor air systems. The Neuton™ signals the cold and hot water control valves to release only enough water of each temperature to maintain the desired chilled beam water temperature to avoid beam condensation. Generally, the ideal chilled beam water temperature is 58°F (for cooling) and 100°F (for heating). Ideal water temperature is achieved by circulating water to chilled beams and only adding hot and cold water as needed. The Neuton™ is able to modulate water flow with the help of a high-efficiency ECM pump, which determines the optimum flow for a given zone. By modulating zone flow and temperature, instead of turning the water on and off, the Neuton™ saves a considerable amount of energy.

The Neuton™ gives users remote access control to the water flow and the water temperature of a zone or zones of chilled beams, with its powered integrated direct digital controller. Controls for operating chilled beam systems at their optimal performance are built into the Neuton™, eliminating the need for any additional design and implementation of controls. The Neuton's™ integrated controls communicate with the dedicated outdoor air system (DOAS), as well as, regulate the chilled and hot water connections and valves, the variable-speed electronically commutated motor pump and smart sensors. Smart sensors enable the Neuton™ to adjust water flow and temperatures based on the amount of people currently in a zone. In addition to being able to communicate with the connected chilled beam system and DOAS, the Neuton™ comes with a port designed to communicate with other devices in the building through BACnet over MS/TP (LON available).

The FläktGroup SEMCO Neuton™, plug-and-play chilled beam pump module, takes the worry out of chilled beams. A revolutionary invention, the Neuton™, is the only chilled beam pump module on the market, that enables chilled beams to be more cost efficient while effectively eliminating condensation concerns.

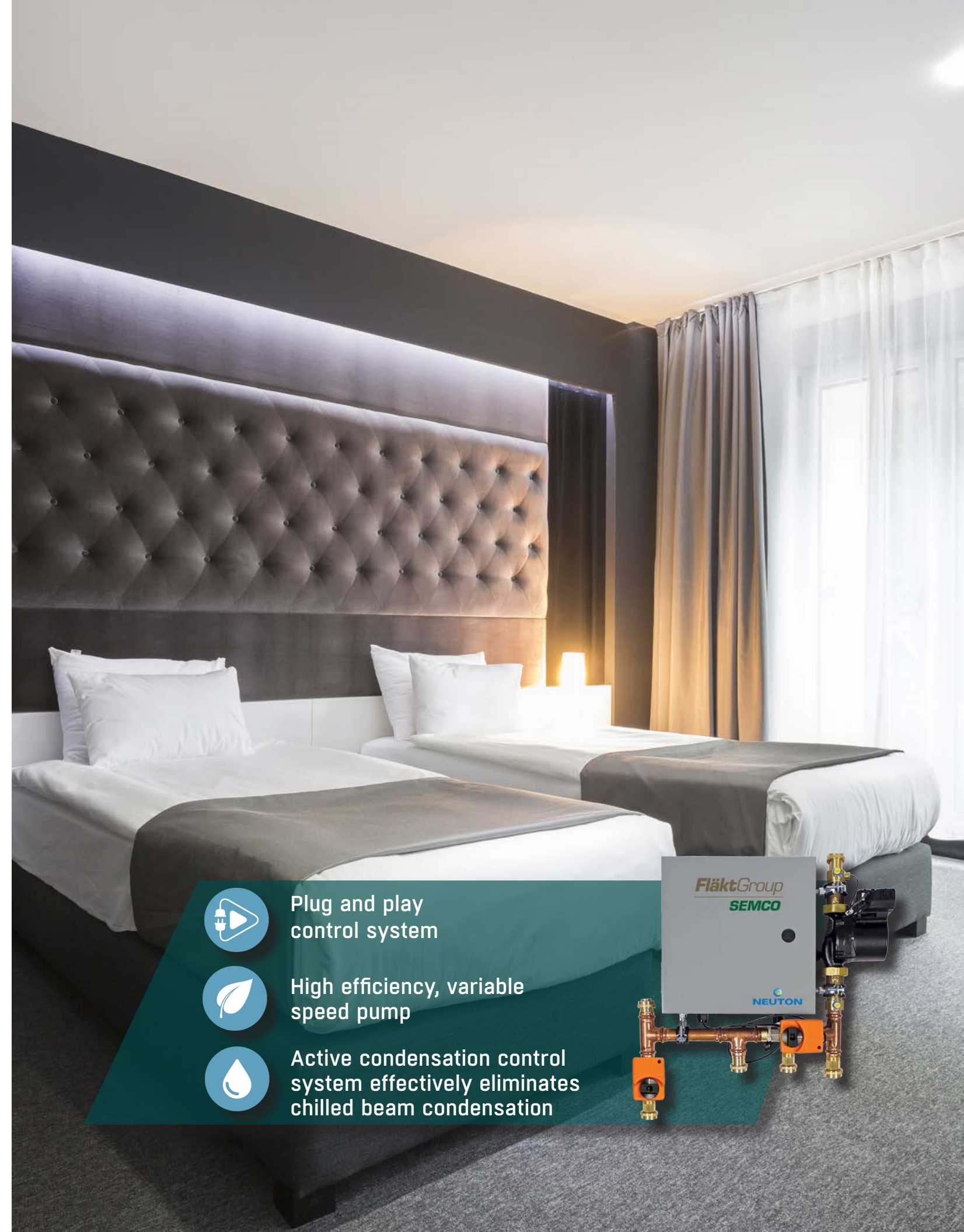

Plug and play control system



High efficiency, variable speed pump



Active condensation control system effectively eliminates chilled beam condensation

7 STEPS TO CHILLED BEAM DESIGN

Chilled beams utilize induction and convection to provide sensible cooling and heating using less fan energy than conventional ducted systems that circulate through a central air handling unit. FläktGroup SEMCO chilled beams were engineered for use in commercial (non-residential) applications, where there is a high temperature load and/or zones that require individual comfort control. If you are incorporating chilled beams into a design, follow the seven steps below:

1) DETERMINE THE TOTAL BUILDING AIRFLOW: (AIRFLOW=½ CFM PER BUILDING SQ FOOTAGE)

- A) On a 100,000 SF building the primary air would be approximately 50,000 CFM.
- B) The answer here is 50% of the air volume of a traditional VAV system (this is conservative).
- C) VAV systems could be designed between 0.8 to 1.2 CFM per SF.

2) DETERMINE % OF OUTDOOR AIR (OA) BASED ON APPLICATION TYPE: HIGH DENSITY IS 100% AND LOW DENSITY IS 50%.

- A) High density: school, hotel, hospital
- B) Low density: office

3) DETERMINE QUANTITY OF BEAMS REQUIRED (AREA OF BEAMS = 5% OF THE BUILDING FLOOR SF)

- A) 100,000 SF building x 5% = 5,000 SF beams
- B) Divided by 2' beam width = 2,500 linear feet of beams

C) Divided by 6' as average beam length = 416 beams

4) FIGURE SENSIBLE LOAD

- A) If engineer hasn't calculated load yet, use 1 CFM per SF at 20 degree delta T (ΔT)
- B) So 100,000 SF would be $20 \Delta T \times 1.0 \text{ CFM} \times 100,000 = 2,000,000 \text{ btuh}$

5) FIGURE PRIMARY AIR TONNAGE

- A) Since schools are 100% OA (STEP 2A), assume a Pinnacle® ventilation system (PVS) at 40 tons* per 10,000 CFM.
- B) School will be 50,000 CFM (STEP 1A)
- C) $40 \text{ tons} \times 5 = 200 \text{ tons of OA}$
- D) Since offices will be 50% OA (STEP 2B), assume a PVS at 40 tons* per 10,000 CFM (STEPS 1A and 2)
- E) Offices will have 25,000 CFM (STEPS 1A and 2)
- F) $40 \text{ tons} \times 2.5 = 100 \text{ tons of OA}$

*NOTE: 40 tons will vary depending on latitude. The further north, the lower the tons, and the further south the higher the tons.

6) FIGURE BEAM TONNAGE

- A) Assume average ΔT on the water of the coil at 6 degrees
- B)
$$\frac{416 \text{ beams} \times 6 \text{ degrees } \Delta T \times 500}{12,000} = 100 \text{ tons}$$

7) LAYOUT

- A) Layout considers room type and quantity of beams per space (SEE STEP 3).
- B) Short answer is that 10x10 office may only require a single 2x2 beam.
- C) 900 SF classroom only needs 4 beams at 6' or 8'
- D) 1,200 SF classroom only needs 6 beams at 6' or 8'
- E) 1,500 SF open office space needs up to 10 beams depending on loads.

* Skin load is the 3 ft. perimeter just inside the glass/ exterior wall s that has a slightly different temperature than the interior of a space does.

If all seven steps are followed, you will be able to start the conceptual design phase with a building owner and the building's architectural plans, an engineer is not needed at this point in the process. If the steps are followed correctly the results will be on the conservative side, typically they will have a 10% safety factor and a reduction in the number of chilled beam capacity and quantity.

After the seven steps are calculated, the type of ancillary central plant approach is determined. Some of the options include:

- Traditional chiller/boiler with pump modules
- Multiple modular chillers to increase efficiency and decrease pipe size.
- DX dedicated outdoor air system approach with air cooled chiller just for the chilled beams.

The seven step method is preferred by the engineers working on the design, because it does not limit them to a single design approach. Engineers will instead be able to choose between air cooled by a chiller or geothermal cooling, determining which will be more beneficial to their design.

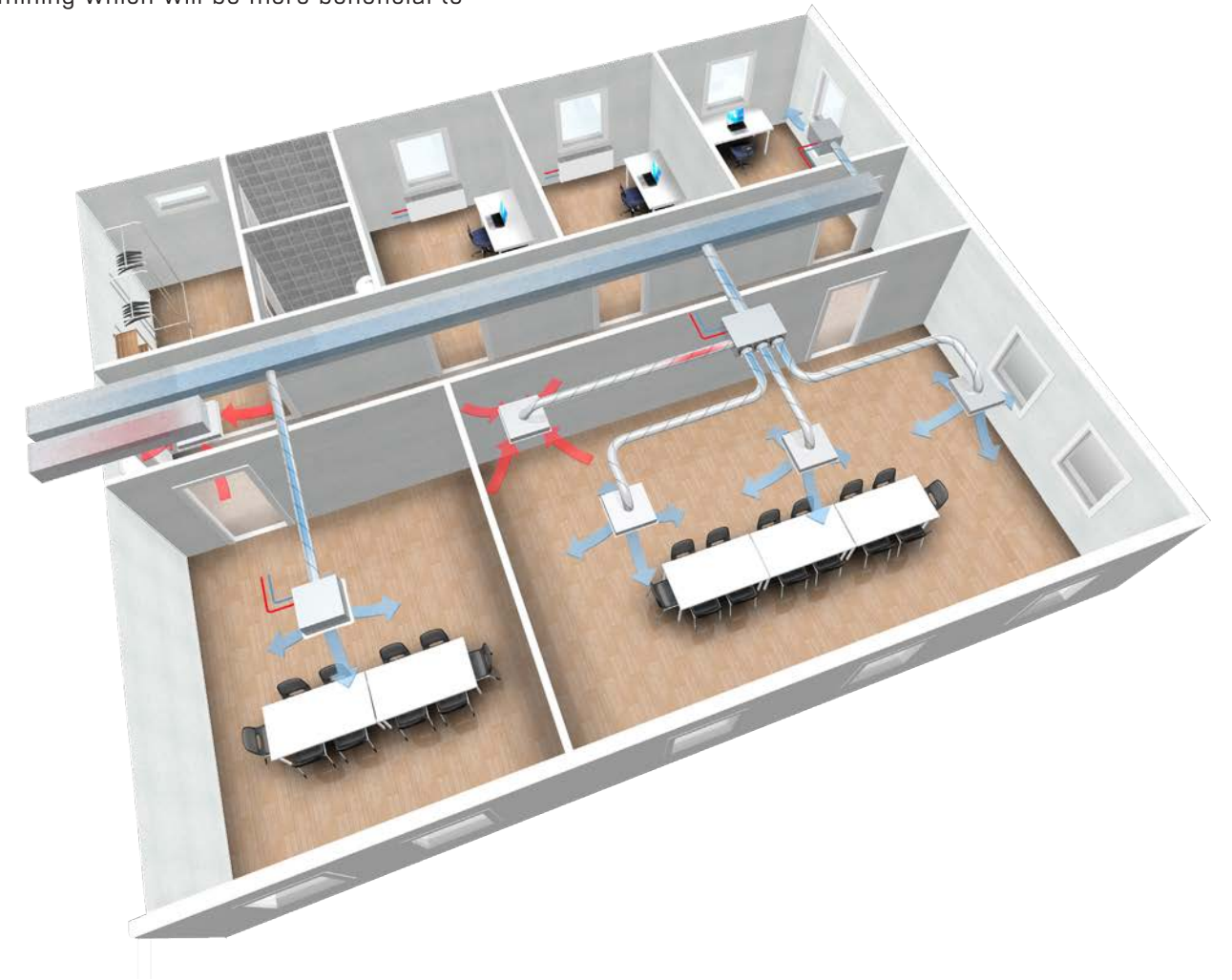

APPLICATIONS FOR CHILLED BEAMS



OFFICE BUILDINGS

Improves indoor air quality by maintaining a comfortable working environment, increasing office productivity. Chilled beams also enhances the office's aesthetic appeal.

HEALTHCARE FACILITIES & LABS

Chilled beams ensure that patients and staff are comfortable, while emitting minimal sound. When coupled with the FläktGroup SEMCO Ascendant™ or Pinnacle®, chilled beams can help with energy recovery and eliminating air contaminants.



HOTELS & RESTAURANTS

Chilled beams quietly, improve indoor air quality by maintaining a comfortable environment for guests and staff, while helping to eliminate odors.

EDUCATION

Chilled beams help provide students with the best possible learning environment. Classrooms are cooled or heated based on classroom occupancy, to ensure students and teachers are comfortable. Adding a Pinnacle® or 3fficiency™ to a chilled beam system will also improve energy efficiency and virtually eliminate the contamination of pathogens and pollutants in the air.



INDUSTRIAL

Chilled beams ensure that a n industrial facility is well ventilated and that areas are comfortable for workers and machinery.

PUBLIC GATHERING PLACES

Improves indoor air quality and ventilation by maintaining a comfortable environment.



SHOPPING CENTERS

Chilled beams ensure that shopping centers are well ventilated and that the environment is comfortable for both shoppers and workers.

EXCELLENCE IN SOLUTIONS

FläktGroup SEMCO delivers smart, energy-efficient, air-quality solutions to support every building application. We offer our customers innovative technologies, high-quality products and outstanding performance supported by more than fifty years of accumulated industry experience. The broadest offering on the market and a strong market presence in 65 countries worldwide guarantees that we are always by your side, ready to deliver: Excellence in Solutions.

FläktGroup SEMCO

Corporate Headquarters
1800 East Pointe Drive
Columbia, Missouri 65201 USA

573.443.1481

sales.semco@flaktgroup.com

To learn more about FläktGroup SEMCO offerings and to contact your nearest representative please visit

www.semcohvac.com

© Copyright 2022 SEMCO LLC. All Rights Reserved. SEMCO embraces a policy of continuous development and improvement, the right is reserved to supply products which may differ from those illustrated and described in this publication. Specifications are subject to change without further notice. Any FläktGroup SEMCO purchase is subject to FläktGroup SEMCO standard terms and conditions. Certified dimensions will be supplied upon request on receipt of order. SEMCO is a registered Trademark of SEMCO LLC. Other trademarks and logos in this publication may be property of SEMCO, LLC, its subsidiaries or any of its related companies and/or other organizations or individuals.

